

L-shaped grab bar made of zinc-plated steel pipe, coated with antimicrobial, biocompatible and warm-to-the-touch vinyl. Equipped with hand shower holder

**Code G40JOL01 Series Maxima**

Net weight kg 3,9 Dimensions [WxDxH] mm 663x100x1203

In use weight capacity *Vertical kg* 150 *Horizontal Kg* 40

**Use and installation info**

*Use* Wall installation

*Cleaning*

Clean using pure water and home disinfectants which have been sufficiently diluted in water. Do not use abrasive detergents and trichloroethylene, oxygenated water or acetone-based solvents.

*Fasteners* Fischer SX 8 6x70 Inox Included with the product

**Packaging information**

*Type of package* Nylon bag in cardboard packaging

*Dimensions [WxDxH] mm* *Weight kg*



**Available colours**

**B1** Blue, **B2** Light blue, **D1** Black, **D2** Grey, **D4** Dark grey, **G1** Green, **G2** Light green, **I1** Ivory, **I2** Biscuit, **R1** Red, **W1** White, **Y1** Yellow, **P4** Prune, **Y3** Light yellow

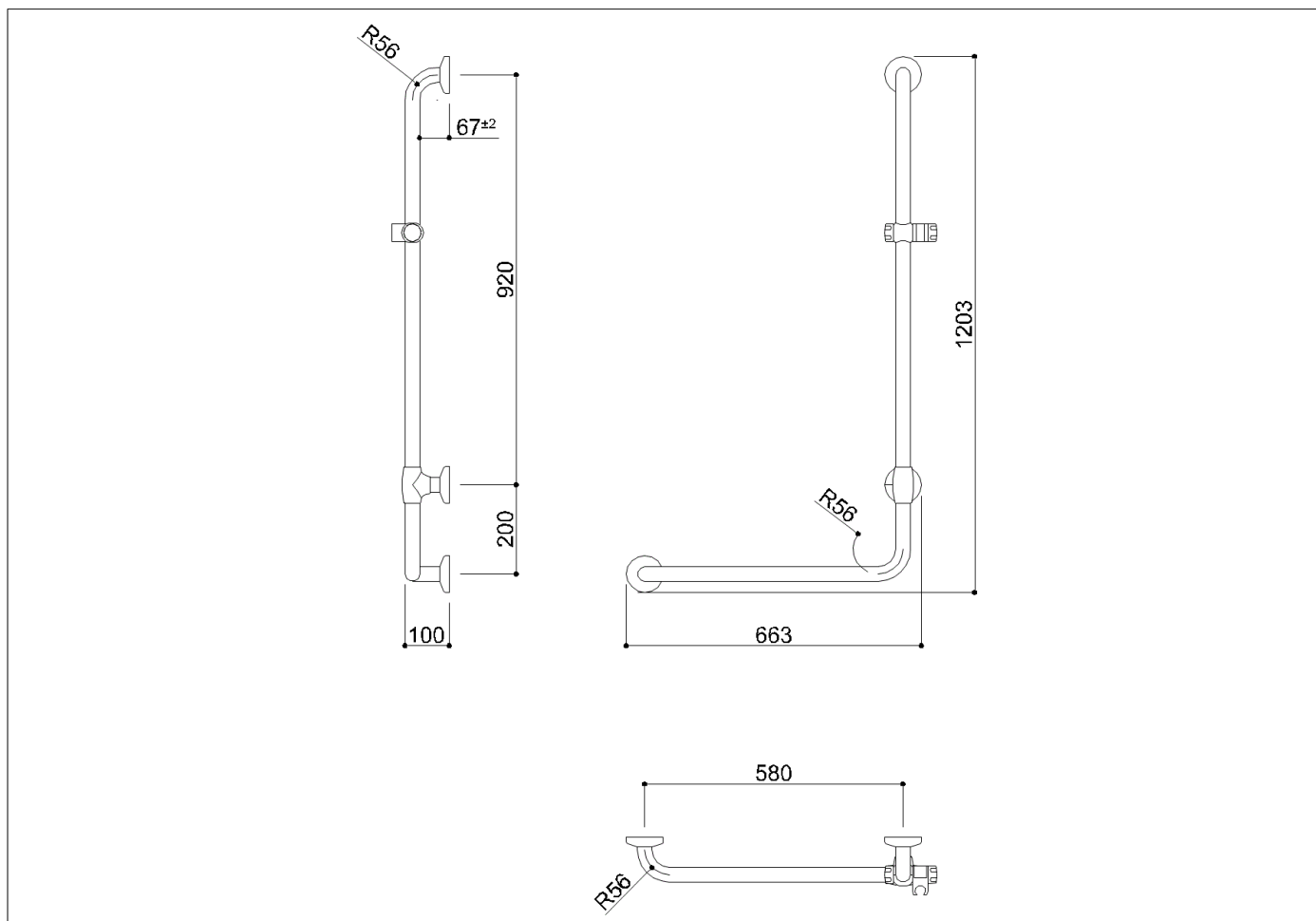

L-shaped grab bar made of zinc-plated steel pipe, coated with antimicrobial, biocompatible and warm-to-the-touch vinyl. Equipped with hand shower holder

**Code G40JOR01 Series Maxima**

Net weight kg 3,9 Dimensions [WxDxH] mm 663x100x1203

In use weight capacity Vertical kg 150 Horizontal Kg 40

**Use and installation info**

*Use* Wall installation

*Cleaning*

Clean using pure water and home disinfectants which have been sufficiently diluted in water. Do not use abrasive detergents and trichloroethylene, oxygenated water or acetone-based solvents.

*Fasteners* Fischer SX 8 6x70 Inox Included with the product

**Packaging information**

*Type of package* Nylon bag in cardboard packaging

*Dimensions [WxDxH] mm Weight kg*



**Available colours**

**B1** Blue, **B2** Light blue, **D1** Black, **D2** Grey, **D4** Dark grey, **G1** Green, **G2** Light green, **I1** Ivory, **I2** Biscuit, **R1** Red, **W1** White, **Y1** Yellow, **P4** Prune, **Y3** Light yellow