

Automatic Wall-mounted Stainless Steel Washbasin Taps SLU 39, SLU 39X

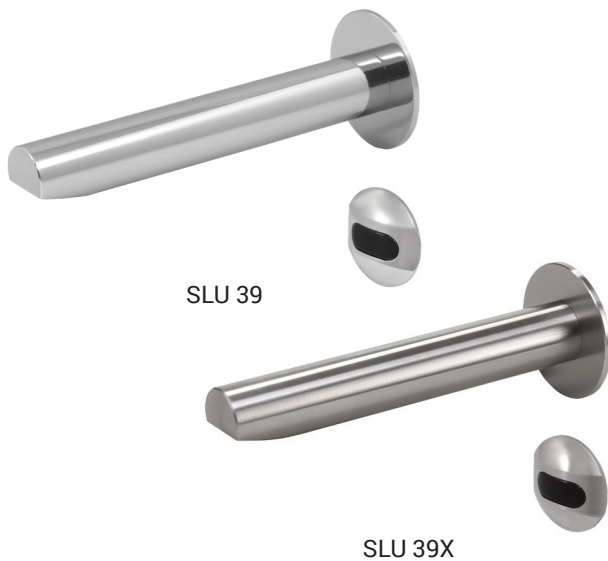

Characteristics



- economical aerator, rate of flow 6 l/min
- hygienic flush
- lead free
- rear assembling from behind wall
- are destined for installation into the wall (necessary to use installation set SLA 52A)
- are destined for installation into the sheets with a max. thickness of 5 mm
- are destined for cold or premixed water
- index X - brushed finish
- water is flowing as long as hands are in the active range
- water stops flowing after removal of hands from the active range of sensor after adjustable time delay (can be set in range 0,25 – 7,75 s)
- function of automatic water stop after 5 minut of continuous flow
- monitoring of battery capacity (for models with index B)
- START/STOP program
- parameter adjustment using by the remote control SLD 03

Installation Drawing

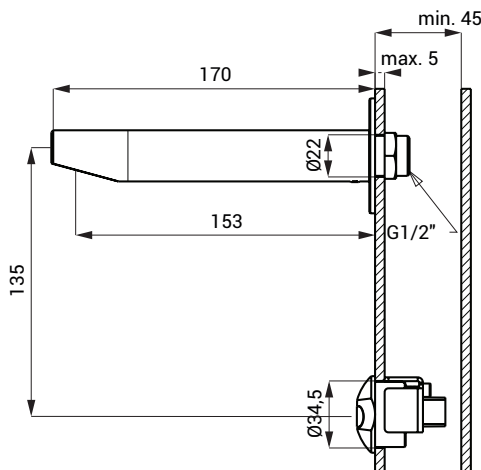

Technical Specification

Operating voltage

- SLU 39, SLU 39X 24 V DC
- SLU 39B, SLU 39BX 6 V

Power input

- operating by 24 V DC 7 W
- operating by 6 V 3 W

Battery life

- 4 pcs. AA alkaline batteries approx. 2 years (100 uses per day)
- AA, 1,5 V, 2700 mAh

Active range

- standard 0,23 - 0,31 m
- START/STOP program 0,05 - 0,15 m

Recommended flow pressure

- 0,1 - 0,6 MPa

Rate of flow

- 6 l/min. (inf. data)

Water inlet

- male thread G 1/2"

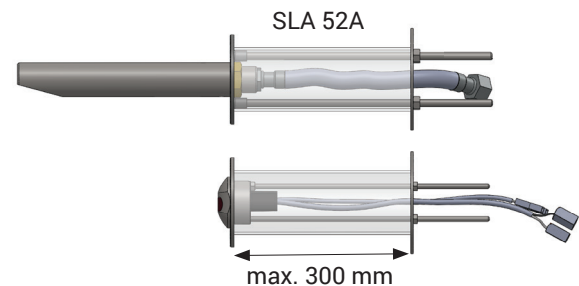

Supply Specification

- SLU 39 - Supply No. 03390
- SLU 39B - Supply No. 03392
- SLU 39X - Supply No. 03391
- SLU 39BX - Supply No. 03393

faucet, head with electronics, electromagnetic valve (1 pcs.), 4 pcs. AA alkaline batteries 1,5 V, 2700 mAh with battery case (for models with index B)

Recommended Accessories

SLZ 01Y	-	Supply No. 05012	power supply 24 V DC for operating of max. 5 pcs. of washbasin taps
SLZ 01Z	-	Supply No. 05011	power supply 24 V DC for operating of max. 9 pcs. of washbasin taps
SLZ 04Y	-	Supply No. 05042	power supply 24 V DC for DIN rail, for operating of max. 5 pcs. of washbasin taps
SLZ 04Z	-	Supply No. 05041	power supply 24 V DC for DIN rail, for operating of max. 9 pcs. of washbasin taps
SLZ 04X	-	Supply No. 10049	power supply 24 V DC for DIN rail, for operating of max. 15 pcs. of washbasin taps
SLZ 06	-	Supply No. 05060	power supply 24 V DC for operating of max. 1 pc. of washbasin tap
SLD 03	-	Supply No. 07030	remote control for an adjustment of parameters
SLT 04	-	Supply No. 09040	thermostatic valve 3/4", rate of flow 28 l/min by the pressure 0,1 MPa
SLT 05	-	Supply No. 09050	thermostatic valve 1/2", rate of flow 42 l/min by the pressure 0,1 MPa
SLT 07	-	Supply No. 09070	thermostatic valve 3/4", rate of flow 43 l/min by the pressure 0,1 MPa
SLT 08	-	Supply No. 09080	thermostatic valve 1", rate of flow 53 l/min by the pressure 0,1 MPa
SLT 09	-	Supply No. 09090	thermostatic valve 5/4", rate of flow 82 l/min by the pressure 0,1 MPa
SLT 10	-	Supply No. 09100	thermostatic valve 6/4", rate of flow 155 l/min by the pressure 0,1 MPa
SLA 52A	-	Supply No. 06520	installation set to the wall
SLA 36	-	Supply No. 06360	set of 4 pcs. alkaline batteries AA, 1,5 V, 2700 mAh (for models with index B)
SLA 56A	-	Supply No. 06560	economical aerator 3,8 l/min
SLA 56B	-	Supply No. 06561	economical aerator 1,9 l/min